



## **SAFETY PRECAUTIONS**



**READ INSTRUCTIONS AND IDENTIFY ALL COMPONENT PARTS BEFORE USING CRIMPER**

**CRIMPER CAN PRODUCE 155 TONS OF FORCE. KEEP BOTH HANDS AWAY FROM PINCH POINTS**

**CONSULT HOSE AND FITTING MANUFACTURER'S SPECIFICATIONS FOR CORRECT MACHINE SETTINGS AND CRIMP MEASUREMENTS**

**ALWAYS WEAR EYE PROTECTION**

# EU32 COMPONENT IDENTIFICATION

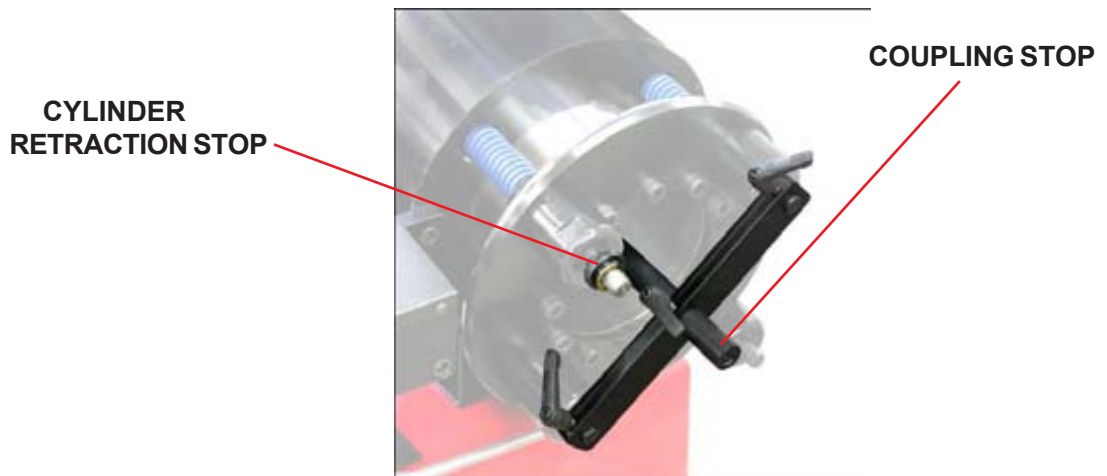

# EU32 SPECIFICATIONS

Master Die Diameter	84mm
Crimping Force	155 Ton
Maximum Hose Diameter (2 Wire)	1½"
Maximum Hose Diameter (4 Wire)	1¼"
Maximum Die Opening (Die Size Plus)	38mm
Maximum Opening w/o Dies	125mm
Length	23½"
Width	15"
Height	18½"
Weight	245 lb
Electrical Power Requirement (Std)	110V
Electrical Power Requirement (Optional)	220V 1 Ph
Pump HP	1 Hp
Oil Capacity	13 Qt
Oil Type	ISO Viscosity Grade 46
Manual/Automatic Crimping	Manual Only
Inch/Metric Settings	Metric Only
Custom Crimp Die Series	84S



# CRIMPING WITH THE . . . . CRIMPER

- Select the correct die set for the combination of hose and fitting being crimped. Consult the hose and fitting manufacturer's specifications for the correct die to use and final crimp diameter required..
- To manually insert the dies, open the master dies to the fully open position, and insert each die finger individually making certain that the die size (number stamped on the face of the die) faces the front of the machine. The die should click into place when it is properly positioned.
- Dies can also be inserted using the Quick Change Tool. Fully open the master dies and slowly close the crimper head making certain that the retaining pins enter the location holes in the master dies. When the head is fully closed, withdraw the Quick Change Tool.
- The final crimp diameter is the closed diameter of the die stamped on the face of the die plus the number shown on the micrometer. See micrometer setting example below

## Micrometer Setting Example

Each 100 on the Micrometer represents 1 mm above the closed diameter of the die set. For example, with a 50mm die installed and the Micrometer set at 250 as shown, the finished crimp diameter would be 52.5 mm. (50mm + 2.5mm)

- Insert the hose and fitting in the crimper head and press and hold the green **Start/Stop** button or press and hold the **Foot Switch**. When the crimper reaches the correct diameter, the crimper will shut off. When possible, the hose fitting should be centered axially in the die set to assure a uniform crimp with minimum taper.
- When the **Hold/Release** valve is in the **Hold** position, the crimper can be jogged into position to allow for more accurate positioning of the fitting in the die set. Turn the **Hold/Release** valve to the **Release** position to allow the dies to retract.
- Measure the finished crimp diameter to be certain that it is within manufacturer's specifications. If the finished diameter is not within specifications, see calibration instructions.

*Note: Due to tolerance variations in hose and fitting combinations, some "offset" may be required for specific combinations of hose and fittings. This does not mean that the crimper is out of calibration.*



# •••••CRIMPER CALIBRATION

## Calibration Check:

The •••••Crimper is calibrated at the factory using a 1/2 inch 2 wire hose and the appropriate fitting. Insert the hose and fitting and press and hold the Start/Stop switch until the crimper shuts off. Measure the finished crimp. If the finished crimp diameter is not within the hose manufacturer's specifications, recalibrate the crimper.

*Note: Due to variations in hose and fitting tolerances, some "offset" may be required to achieve the correct crimp diameter for specific hose and fitting combinations across the range of hose and fittings being crimped. If crimp diameters are consistently too large or consistently too small, the crimper should be recalibrated.*

## Calibration:

While the crimper can be calibrated using any recommended hose and fitting combination, using a hose and fitting combination close to the size most frequently crimped will minimize the offset required for other sizes and combinations of hose and fittings.

- Select a hose and fitting combination recommended by the hose manufacturer and continue to adjust the Crimp Adjustment Micrometer until the correct measured crimp diameter is achieved.

The micrometer in the picture is adjusted to 2.5mm above the die size in the crimper. For example, if there is a 23mm die set in the crimper the crimper would be set to crimp at 23mm + 2.5mm or 25.5mm.

**Note: The number on the Crimp Adjustment Micrometer may not agree with the hose manufacturer's specification at this point.**

- If necessary, loosen the set screw on the knob with a .050 hex key wrench and rotate the knob until the setting on the knob matches the actual diameter of the finished crimp.
- Tighten the set screw
- Calibration is now complete





# SPECIAL FEATURES & MAINTENANCE

## Coupling Stop

- When making repetitive crimps, setting the Coupling Stop eliminated the need to visually align the couplings each time

For repetitive crimps, position the hose and fitting in the correct position and bring the face of the coupling stop against the fitting. This eliminates the need to sight the position of the fitting when making repetitive crimps

Coupling Stop



## Retraction Stop

- When making repetitive crimps, setting the Retraction Stop at a point where the hose and fitting can be conveniently withdrawn without allowing the cylinder to fully retract will greatly reduce the crimp cycle times

Retraction Stop

## Lubrication

- Check the tank dipstick for proper reservoir oil level. If additional oil is required fill with ISO Grade 46 hydraulic oil.

### Crimper Head Lubrication

The Crimper master dies have lubrication passages drilled in the die fingers. This feature makes positive lubrication of the wear surfaces much easier making for longer life of the crimper and smoother operation. Foam pads are furnished between the master die fingers to keep dirt and debris from destroying the die and piston surfaces.

- Move the master dies to a nearly fully closed position exposing lubrication fitting holes in the front of the master dies. Lubricate the master dies with a moly-disulfide lubricant. Failure to use a high quality moly-disulfide lubricant can result in premature wear and possible damage to the master dies and piston surfaces.

- The foam pads may be removed to make certain that the grease passages are open and that grease is getting to the wearing surfaces. Replace the pads as they are critical to protect the wearing surfaces from damage.



Foam Filler Pads



Grease Fitting Holes



Flush Style Grease Coupler Required

# TROUBLESHOOTING

## **PROBLEM: CRIMPER WILL NOT RUN AT ALL**

- The white rocker switch is also a circuit breaker Check to see that the circuit breaker has not been tripped.
- Check the wall outlet. Use of extension cords or outlets with inadequate power can damage the motor . Do not run the crimper from a portable power source.

## **PROBLEM: CRIMP DIAMETER TOO LARGE**

- Check crimper calibration and recalibrate if required.
  - Incorrect die being used. Each die has a range of approximately 3mm (.120 in) above the closed diameter of the die. The closed diameter is the die size stamped on the die face.
  - Incorrect setting of the micrometer Check hose manufacturer's specifications.
  - Inadequate pump pressure. Check oil level in the pump. It should be ½ to 2 inches below the fill plug. Replenish with ISO Viscosity Grade 46 hydraulic oil if necessary
  - Inadequate lubrication of the master dies causing the pump to work harder than normal to reach the required diameter.
  - Inadequate pressure being generated by the pump. This is most likely if the crimper can crimp the smaller size hoses and not the larger hoses. When correctly adjusted, the pump should generate approximately 11,000 psi.
- Do Not adjust pump to produce in excess of 11,000 psi as damage to components or personal injury could result**
- No pressure being generated by the pump. There should be a definite change in pitch of the pump as it cycles into high pressure mode and begins to "work" harder

## **PROBLEM: CRIMP DIAMETER TOO SMALL**

- Check crimp diameter and recalibrate if necessary
- Incorrect die being used (See die range under Crimp Diameter too Large)
- Incorrect setting of the micrometer Check hose manufacturer's specifications.

# COMPONENT IDENTIFICATION

ITEM	PART NUMBER	DESCRIPTION	QTY
1	102071	Cylinder Body	1
2	102782	Ram Wear Ring	1
3	102783	Ram L-Cup Seal	1
4	102231	Cylinder Piston	1
5	102784	Piston Wear Ring	1
6	102784	Piston Seal	1
7	102238	Master Die	8
8	9528K19	3/8 Chrome Steel Ball	8
9	102778	Compression Spring	8
10	91375A682	7/16-20 x 1/2 Std Screw	8
11	102793	Grease Filling	8
12	102793	Master Die Spring	16
13	103570	Front Plate	1
14	102229	Front Plate	1
15	31828	5/8-11 X 2.24 SHCS	12
16	102230	Back Plate	1
17	103019	Dial Micrometer Stop	1
18	91251A269	3/8-18 X 1.24 SHCS	12
19	9445A247	1/4-20 X 0.75 Nyloc Std Screw	3
20	102780	Retraction Spring	4
21	102780	Retraction Spring	4
22	102232	Retraction Spring Cup	4
23	102644	Retraction Stop Rod	1
24	92815A127	Knurled Hand Nut	1
25	98407A138	Retaining Ring	1
26	102813	CCSO Basecup Support Bracket	1
27	102813	CCSO Basecup Support Bracket	1
28	102812	Pusher Retaining Pin	1
29	KHA-108	Adjustable Clamping Handle	3
30	91253A624	3/8-16 x 1" FHCS	1
31	101909	Backstep Guide Bushing	1
32	9452K29	210B70 O-Ring	1

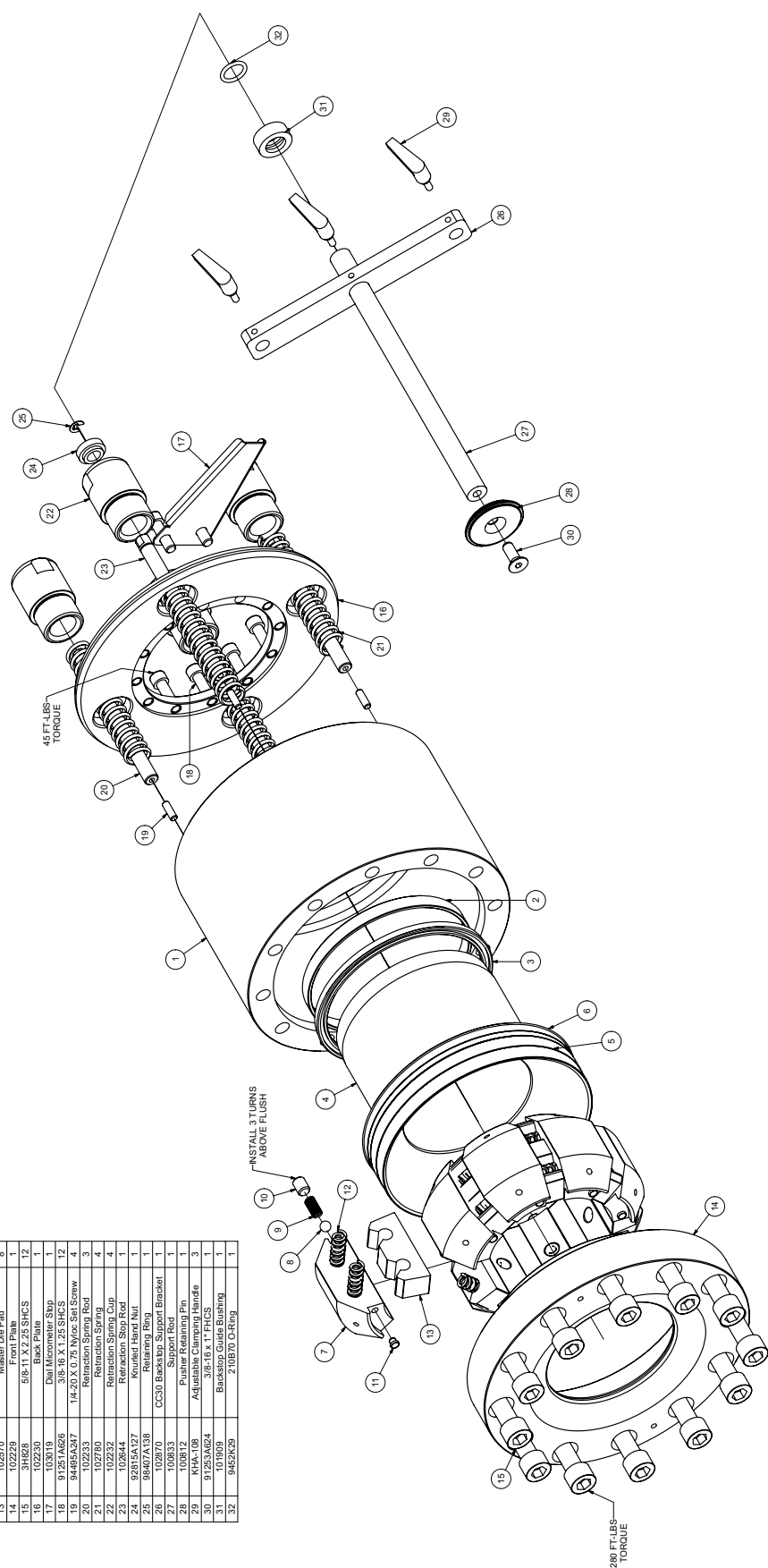



# COMPONENT IDENTIFICATION

.....Crimper Assembly (102642)				.....Crimper Assembly (102642)			
ITEM	PART NUMBER	DESCRIPTION	QTY	ITEM	PART NUMBER	DESCRIPTION	QTY
1	VEP-1-CMS-CC30-A1	1HP Pump Assembly	1	12	92865A712	1/2-13 x 1 HHCS	2
2	101420	4 Gallon Reservoir	1	13	102643	3/8 High Pressure Tubing	1
3	101438	Electrical Box Assembly	1	14	52215K334	Elbow Compression Fitting	1
4	92323A512	1/4-20 x 1/2 HHFCS	10	15	52215K324	Straight Compression Fitting	1
5	101978	2W/2P Hold/Release Valve	1	16	102239	Crimper Cylinder Assembly	1
6	101340	1/4-20 x 2.25 HHFCS	4	17	91251A624	3/8-16 x 1 SHCS	4
7	102577	Crimper Head Bracket	1	18	102641	Protective Front Cover	1
8	92865A622	3/8-16 x 3/4 HHCS	2	19	92949A537	1/4-20 x 1/2 BHCS	4
9	91102A760	3/8 Lock Washer	2	20	103018	Micrometer Rear Bracket	1
10	90108A417	3/8 Flat Washer	2	21	102941	Dial Micrometer Assembly	1
11	91102A770	1/2 Lock Washer	2				

