

CONAH

SAHR-15-12

| | |
|-------------------------|------------------|
| Used For | Air Hose Reel |
| Hose Material | Rubber |
| Hose Working Length | 15mtrs |
| Hose Internal Bore | 1/2" |
| Inlet | 1/2" BSP Female |
| Outlet | 1/2" BSP Male |
| Maxium Working Pressure | 20 Bar (290 psi) |



Features

- Heavy ribbed steel plate
- Spring locates in the middle
- Four-direction non-snag hose rollers
- Adjustable arm guide
- Elegant appearance, dual pedestal base
- Special swivel joint
- Ball bearing swivel joint structure
- Corrosion resistant powder coating

Benefits

- Strong support
- Ensure reel stability
- Reduces Hose wear
- Enable wall, floor, ceiling and pit mounting
- Versatile usage
- Easy maintenance and repair
- Reduces friction extending service life
- Used in most environments

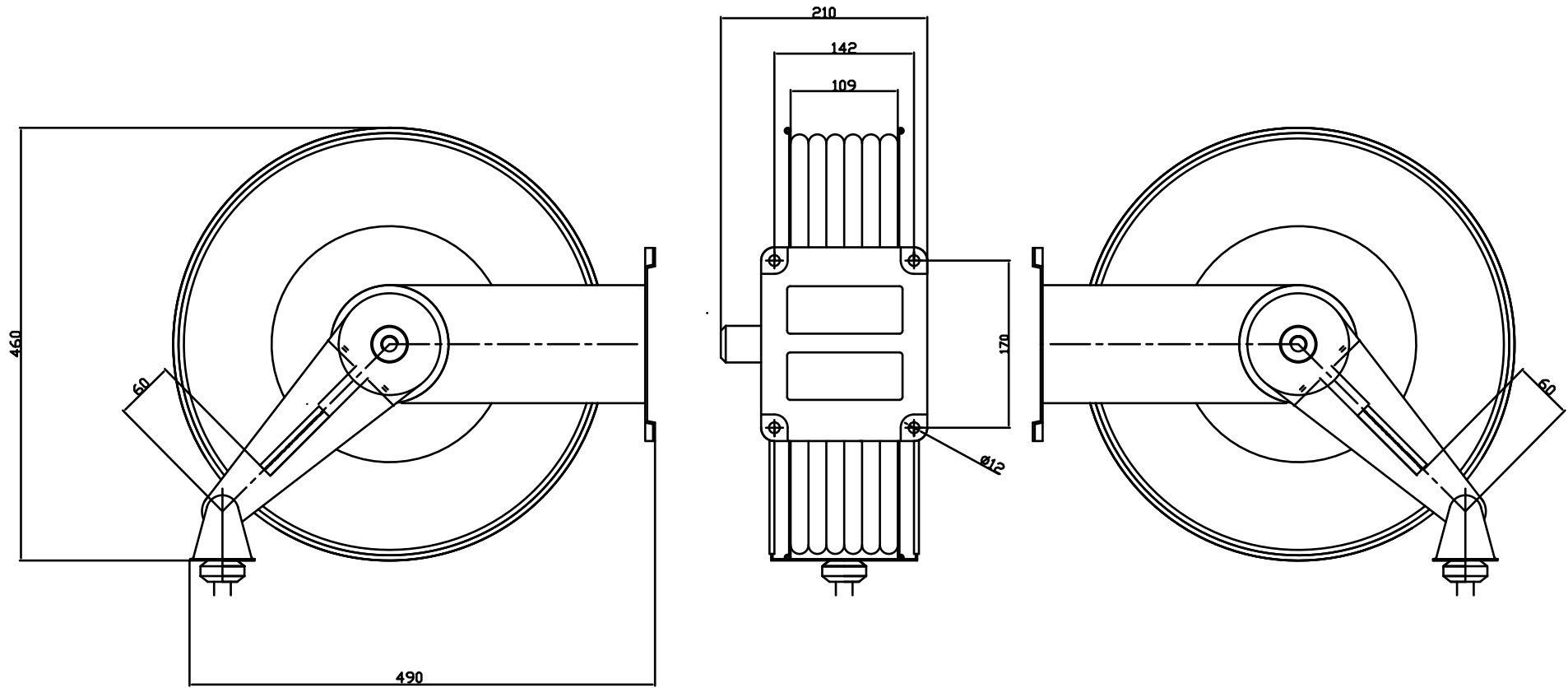

| | | | | |
|-------------------------|---------|------|----------|-------------------------------|
| UNLESS OTHERWISE STATED | | NAME | DATE | TITLE |
| DIMENSIONS IN MM | DRAWN | DB | 27032013 | CONAH HOSE REEL |
| TOLERANCES | CHECKED | | | |
| FRACTIONAL +/- 0.10 | ENG APP | | | SIZE DWG NO |
| 2 DECIMAL PLACE +/-0.1 | MFG APP | | | A SAHR-15-12 |
| MATERIAL | QA | | | COMMENTS |
| | | | | SCALE 1:1 WEIGHT SHEET 1 OF 1 |