

Valves

Series RFU - RFO

Unidirectional and bidirectional flow control valves

Ports M5, G1/8, G1/4

Nominal diameter M5 = 1,5 - G1/8 = 2 & 3 mm - G1/4 = 4 and 6 mm

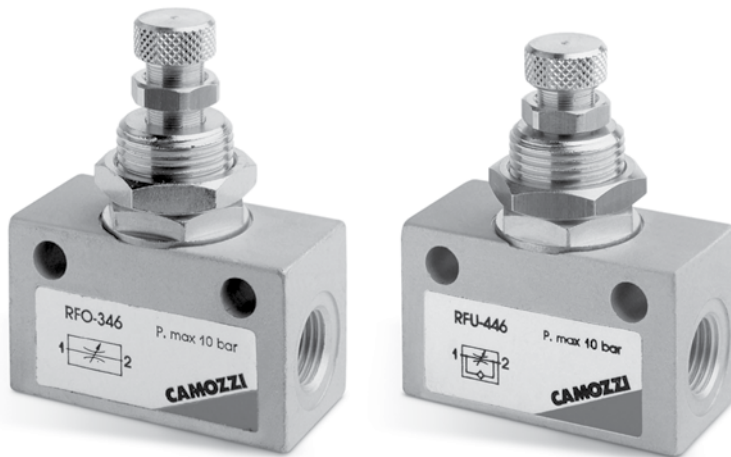

» Series RFU: unidirectional flow control valves

» Series RFO: bidirectional flow control valves

The unidirectional flow controllers are equipped with M5, G1/8 and G1/4 ports, each of which is available with two different types of adjustment (see diagrams), except for the M5. They are used mainly for controlling the speed of cylinders. They may be mounted on control panels or cylinders, as required.

GENERAL DATA

Construction	needle - type
Valve group	unidirectional and bidirectional controller
Materials	aluminium body - OT58 (brass) needle - NBR seals
Mounting	by through - holes in valve body or control panel
Threaded ports	M5 - G1/8 - G1/4
Installation	as required
Operating temperature	0°C + 80°C (with dry air - 20°C)
Operating pressure	1 + 10 bar
Nominal pressure	6 bar
Nominal flow	see graph
Nominal dia.	M5 = 1,5 - G1/8 = 2 or 3 mm - G1/4 = 4 or 6 mm
Fluid	filtered air

CODING EXAMPLE

RF

U4

8

2

RF

SERIES:
RF

U4

FUNCTION:
U4 = unidirectional
O3 = bidirectional

8

PORTS:
8 = G1/8
4 = G1/4
5 = M5

2

FLOW CONTROL RANGE:
2 = \varnothing 2 max
3 = \varnothing 3 max
4 = \varnothing 4 max
6 = \varnothing 6 max

To ensure the right choice of unidirectional flow controller, proceed as follows: calculate the quantity of air in NI/min (see cylinder Table); determine the stroke time of the cylinder; refer to graph to see which controller is the right type.

UNIDIRECTIONAL AND BIDIRECTIONAL FLOW CONTROLLERS

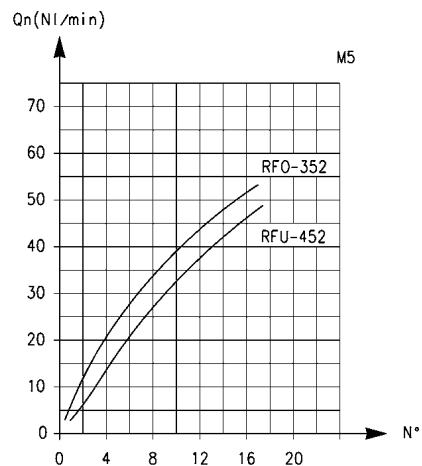
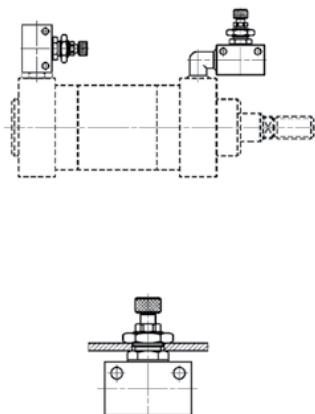

MOUNTING EXAMPLES

RFU 452-M5 - RFO 352-M5

UNIDIRECTIONAL AND BIDIRECTIONAL FLOW CONTROLLERS

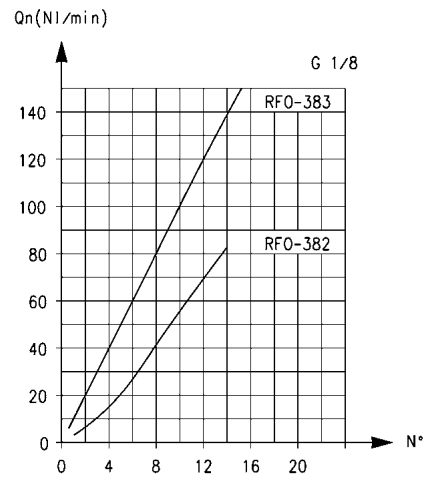
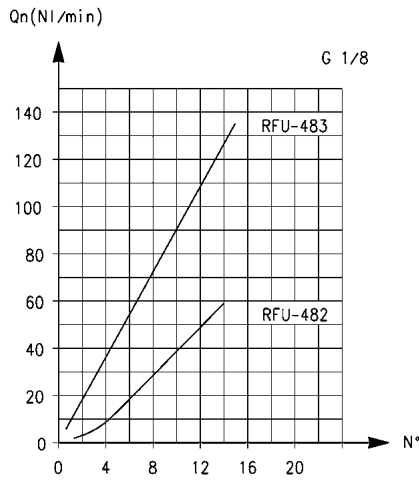

RFU 482-1/8 - RFU 483-1/8
 Mod. RFU 482 flow from 2 → 1 needle type OPEN = 149 NI/min
 CLOSED = 130,5 NI/min
 Mod. RFU 483 flow from 2 → 1 needle type OPEN = 180 NI/min
 CLOSED = 140 NI/min
 N° = number of screw turns
 NB: Qn is determined with a pressure of 6 bar at the inlet and $\Delta P = 1$ bar at the outlet.

RFO 382-1/8 - RFO 383-1/8
 N° = number of screw turns
 NB: Qn is determined with a pressure of 6 bar at the inlet and $\Delta P = 1$ bar at the outlet.

UNIDIRECTIONAL AND BIDIRECTIONAL FLOW CONTROLLERS

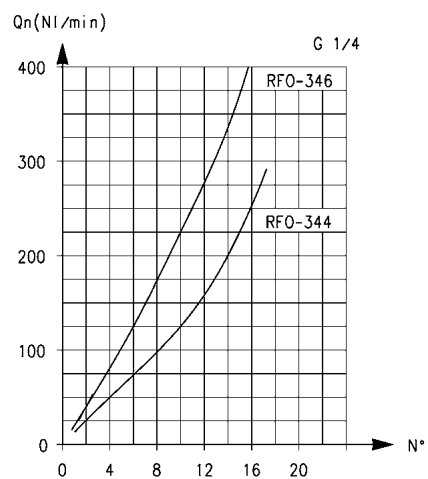
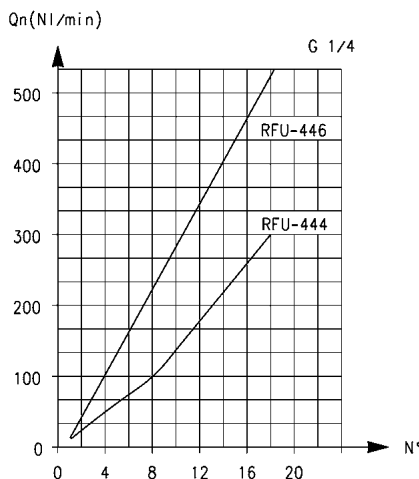

RFU 444-1/4 - RFU 446-1/4
 Mod. RFU 444 flow from 2 → 1 needle type OPEN = 680 NI/min
 CLOSED = 534 NI/min
 Mod. RFU 446 flow from 2 → 1 needle type OPEN = 680 NI/min
 CLOSED = 534 NI/min
 N° = number of screw turns
 NB: Qn is determined with a pressure of 6 bar at the inlet and $\Delta P = 1$ bar at the outlet.

RFO 344-1/4 - RFO 346-1/4
 N° = number of screw turns.
 NB: Qn is determined with a pressure of 6 bar at the inlet and $\Delta P = 1$ bar at the outlet.

Unidirectional flow controller Series RFU



To regulate the speed of a cylinder, the air flow from the chamber which is being discharged must be regulated.

For this reason, the unidirectional flow controller must be connected as follows:

- connect the threaded outlet marked 1 to the cylinder inlet
- connect the threaded outlet marked 2 to the valve user port.

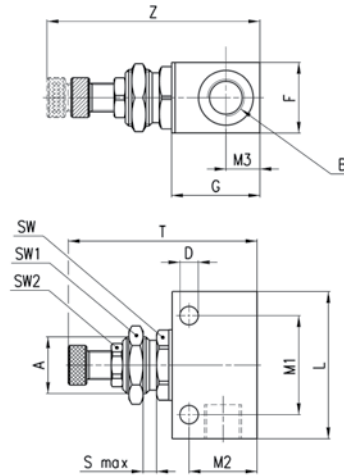

DIMENSIONS

Mod.	\varnothing N	A	B	D	F	G	L	M1	M2	M3	T	Z	S _{Max}	SW	SW1	SW2
RFU 452-M5	1,5	M10x1	M5	4,2	14	16	26	18,5	13,2	7	39	44,5	3	12	14	8
RFU 482-1/8	2	M12x1	G1/8	4,5	16	21	34	24,5	16,5	8	46	51	4	14	17	9
RFU 483-1/8	3	M12x1	G1/8	4,5	16	21	34	24,5	16,5	8	46	51	4	14	17	9
RFU 444-1/4	4	M20x1,5	G1/4	6,5	25	25	52	35	24	12	60	69	7	22	24	14
RFU 446-1/4	6	M20x1,5	G1/4	6,5	25	25	52	35	24	12	60	69	7	22	24	14

Bidirectional flow controller Series RFO



The bidirectional flow controller is suitable for regulating the air flow in both directions and for pressurising or depressurising containers.

When choosing the model, reference must always be made to the M5, G1/8 and G1/4 graph, although it is necessary to know in advance the number of litres of air to be regulated per unit of time.

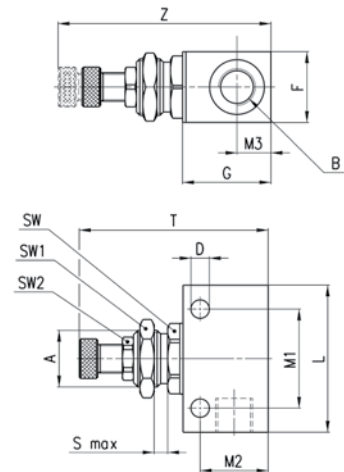

DIMENSIONS

Mod.	\varnothing N	A	B	D	F	G	L	M1	M2	M3	T	Z	S _{Max}	SW	SW1	SW2
RFO 352-M5	1,5	M10x1	M5	4,2	14	16	26	18,5	13,2	7	39	44,5	3	12	14	8
RFO 382-1/8	2	M12x1	G1/8	4,2	16	21	34	24,5	16,5	8	46	51	4	14	17	9
RFO 383-1/8	3	M12x1	G1/8	4,5	16	21	34	24,5	16,5	8	46	51	4	14	17	9
RFO 344-1/4	4	M20x1,5	G1/4	6,5	25	30	52	35	24	12	60	69	7	22	24	14
RFO 346-1/4	6	M20x1,5	G1/4	6,5	25	30	52	35	24	12	60	69	7	22	24	14