

Pressure

Vacuum

Level

Flow

Temperature

Displays

Pressure switch with DIN Plug

PSM & PSP

Diaphragm & Piston type pressure switches with adjustable differential¹.

- 0.2 - 300 bar adjustment range
- Over pressures up to 600 bar
- Standard DIN Plug (IP 65)
- Change-over contacts (SPDT)
- Suitable for gases and liquids
- Integral 'O' ring high pressure seal
- Stainless steel & vacuum option
- Optional snubber
- Vacuum switch option - see [DataFax 1045](#)

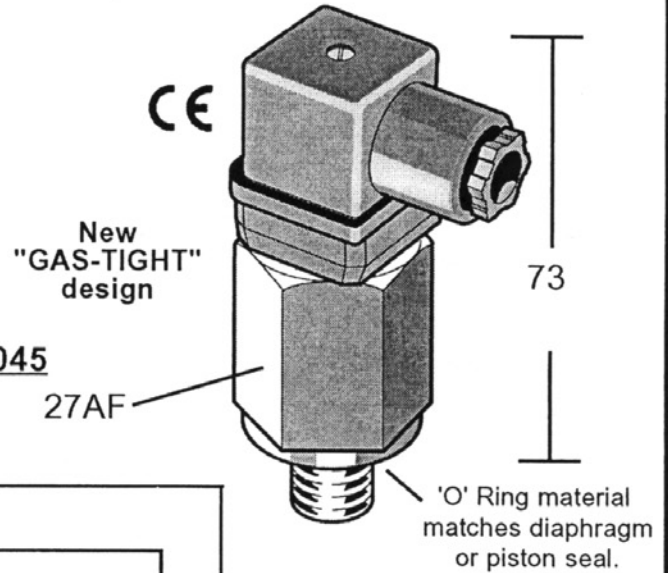

Example

PSM 10 N - 1/4P STL - -

Model

Adj. range

Diaphragm/Piston seal	
Nitrile (std) -5° to +90°C	N
Nitrile -40° to +140°C	T
Viton -5° to +90°C	V
Silicon -30° to +120°C	S
Neoprene -10° to +90°C	O
EPDM -20° to 110°C	E
S/steel (PSM2 & 10 only)	I

Threads	
1/8 BSP	1/8P
1/8 NPT	18NPT
1/4 BSP(std)	1/4P
M10 x 1	M10
M12 x 1.5	M12

Contact option	
Silver (std)	-
Gold	G

Special options	
No special option (std)	-
De-greased ⁽¹⁾	SG
Tested for gas	TG
Snubber	SM

Body material	
Steel-zinc plated (std)	STL
Brass ⁽²⁾ (max 80bar)	BRS
Stainless steel, 303 ⁽³⁾	303
Stainless steel, 316 ⁽³⁾	316

Cable glands	
Pg9 (std)	-
Pg11	11

Model	Adj range Bar	Tolerance Bar	Maximum pressure ⁽³⁾	Diaphragm or Piston	Body material
PSM2	0.2 - 2	+/- 0.2	300 bar ⁽²⁾	Diaphragm	Steel
PSM10	1 - 10	+/- 0.4	300 bar ⁽²⁾		
PSM50	10 - 50	+/- 2.0	300 bar		
PSM100	10 - 100	+/- 3.0	300 bar		
PSP150	30 - 150	+/- 5.0	300 bar	Piston	
PSP300	50 - 300	+/- 15.0	600 bar		

NOTE: The differential (hysteresis) can only be adjusted by PVL, please advise your requirements.
⁽²⁾ Brass bodies have a maximum operating pressure of 80bar, all switches are available in s/steel.

STANDARD SWITCHES

Diaphragm/Piston seal = Nitrile (NBR)
 Body = Steel, zinc plated
 Thread = 1/4" BSP (parallel)
 Cable gland = Pg9

FREE ADJUSTMENT

Adjustment is free of charge, please advise Rising and/or Falling pressure.
 To adjust these switches yourselves, please see [DataFax 1023A](#)

- (1) De-greased for use with Oxygen up to 200 bar - PSM 2 to PSM 100 only
- (2) Brass maximum pressure = 80 bar
- (3) Contact us for s/steel maximum pressures

Switch electrical rating	250Vac/6A (res) 2A (ind)	Diaphragm/Piston material	Nitrile (Standard) see options
Protection	IP65 (Pg9 gland standard)	Body material	Brass, Steel or S/Steel
Pressure adjustment range	0.2 to 300 bar	Thread	1/4" BSP (Standard)
Maximum pressure	Up to 600 bar	Temperature range	See diaphragm/piston spec
Hysteresis = 10%FS (Std)	Factory adjustable 10 - 30%	Tightening torque	5 Kgm

For Prices please see [Datafax 1023P](#)

Adjustment instructions for models - PSM & PSP

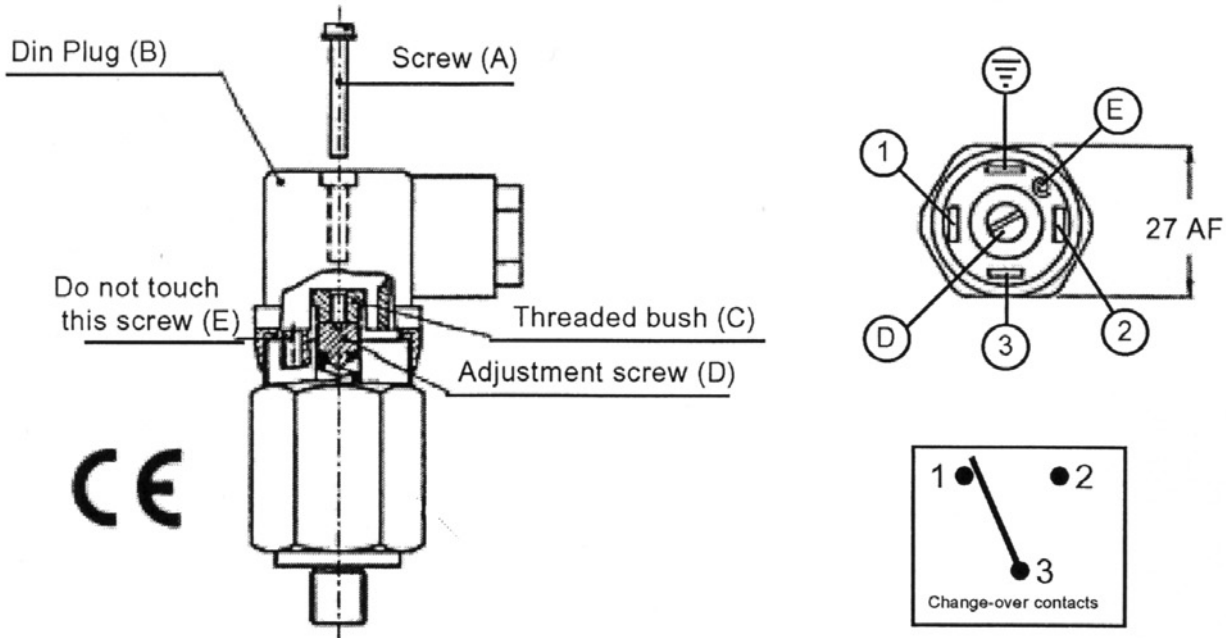

Adjustment instructions if the DIN plug is already connected to an electrical supply.

- 1) Loosen screw (A) and remove DIN Plug (B)
- 2) Remove threaded bush (C) 8mm AF
- 3) Replace DIN Plug and insert a 3mm Ø screwdriver through retaining screw hole
- 4) Turning the adjustment screw (D) clockwise increases the set-point and anticlockwise decreases the set-point.
- 5) Once the set-point has been achieved, operate the switch 3 to 4 times to ensure that the set-point is stable. Repeat step 4) if necessary.
- 6) After adjustment it is advisable to seal the adjustment screw (D) with a small dab of quick drying paint to prevent accidental movement of the screw and for security purposes.
- 7) Refit the threaded bush (C) and the Din Plug (B) and tighten screw (A)

Note 1

If an electrical supply is not available, then either use a multi-meter or a low voltage supply connected across the terminals with a test lamp/buzzer in circuit. Maximum permissible switching capacities must be observed - see technical data.

Note 2

Hysteresis adjustment can only be adjusted at the factory - Do not interfere with the small screw (E) as the switch can be easily damaged. Please contact your supplier for assistance.

Switch electrical rating	250Vac/6A (res) 2A (ind)	Diaphragm/Piston material	Nitrile (Standard) see options
Protection	IP65 (Pg9 gland standard)	Body material	Brass, Steel or S/Steel
Pressure adjustment range	See DataFax 1023	Thread	1/4" BSP (Standard)
Maximum pressure	See DataFax 1023	Temperature range	See diaphragm/piston spec
Hysteresis = 10%FS (Std)	Factory adjustable 10 - 30%	Tightening torque	5 Kgm