

Stainless Steel Adjustable Airmover SS60A



Material: Stainless Steel (Grade 304)

Weight: 2.5Kg

Standard Gap: Adjustable

dB(A) at: 5.5 bar is 80

Shims: Not Applicable

Standard Inlet Thread: G 3/8"

Options: 3/8" NPT

Please specify on order: 3/8" NPTF

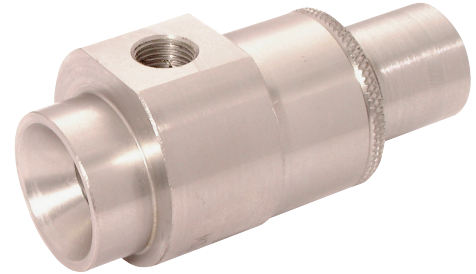

Bar	Vol in m ³ /min	Vol out m ³ /min
1.38	0.280	4.191
2.76	0.476	7.561
4.14	0.654	9.231
5.52	0.841	11.327

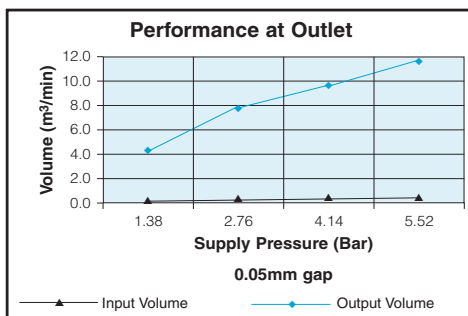
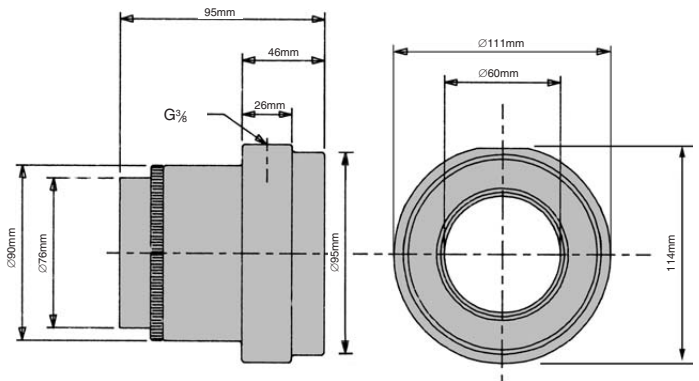

Stainless Steel, BSPP

Part Number	Thread	DBA
BR-SS60A	3/8"	80

Stainless Steel Adjustable Airmover SS75A



Material: Stainless Steel (Grade 304)

Weight: 4.5Kg

Standard Gap: Adjustable

dB(A) at: 5.5 bar is 81

Shims: Not Applicable

Standard Inlet Thread: G 1/2"

Options: 1/2" NPT

Please specify on order: 1/2" NPTF

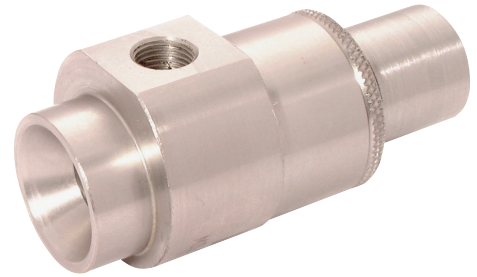

Bar	Vol in m ³ /min	Vol out m ³ /min
1.38	0.425	6.230
2.76	0.651	9.203
4.14	0.906	12.035
5.52	1.133	14.866

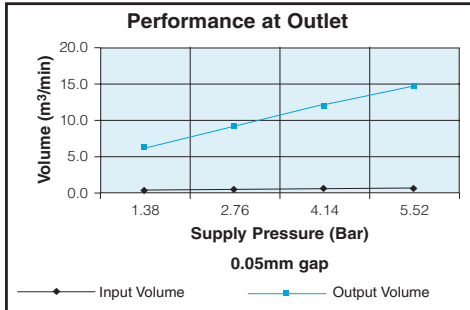
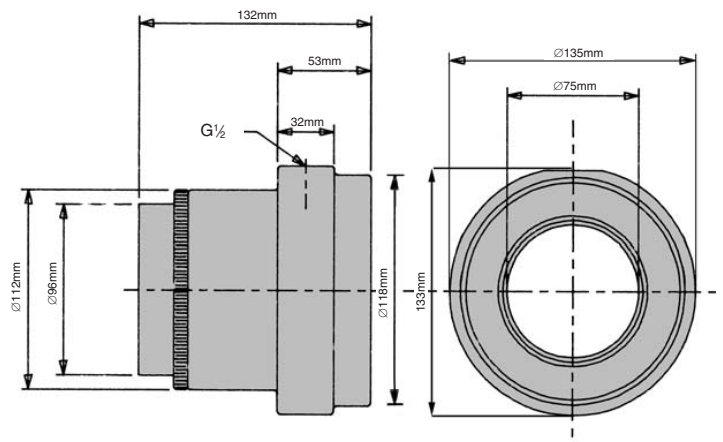

Stainless Steel, BSPP

Part Number	Thread	DBA
BR-SS75A	1/2"	81