

# Precision Regulators



The newly developed precision regulator has been tested rigorously in our pneumatic lab. The product description is as follows:

## Product Features

- High pressure regulating accuracy and rapid response
- Good pressure and flow characteristics
- Easy installation; can be installed independently by self trestle or directly with existing filter module-type combination components
- High pressure, medium pressure and low pressure available

## Ordering Code

**GPR - 300 - L - 06**

### Model

200 : 200 Precision Regulator  
 300 : 300 Precision Regulator  
 400 : 400 Precision Regulator

### Regulating Pressure Range

200 & 300:  
 L : 0.005 – 0.2 MPa  
 M : 0.01 – 0.4 MPa  
 H : 0.01 – 0.8 MPa  
 400:  
 L : 0.01 – 0.2 MPa  
 M : 0.01 – 0.4 MPa  
 H : 0.01 – 0.8 MPa

### Port Size

06 : 1/8"  
 08 : 1/4"  
 10 : 3/8"  
 15 : 1/2"

## Specifications

Model	GPR20006	GPR30008	GPR40008	GPR40010	GPF40010
Port size*	PT 1/8	PT 1/4	PT 1/4	PT 3/8	PT 1/2
Maximum supply pressure	1.0 MPa (145 psi)				
Pressure range	L (low)	0.005 to 0.2 MPa		0.01 to 0.2 MPa	
	M (medium)	0.01 to 0.4 MPa			
	H (high)	0.01 to 0.8 MPa			
Sensitivity	Within 0.2% of full span				
Repeatability	Within $\pm 0.5\%$ of full span				
Air consumption	< 4.0 l/min (ANR)		< 9.5 l/min (ANR)		< 11.5 l/min (ANR)
Temperature range	-20 to +70°C (no freeze)				

\*PG thread and NPT thread available.

## Dimensions

### GPR200 Dimensions

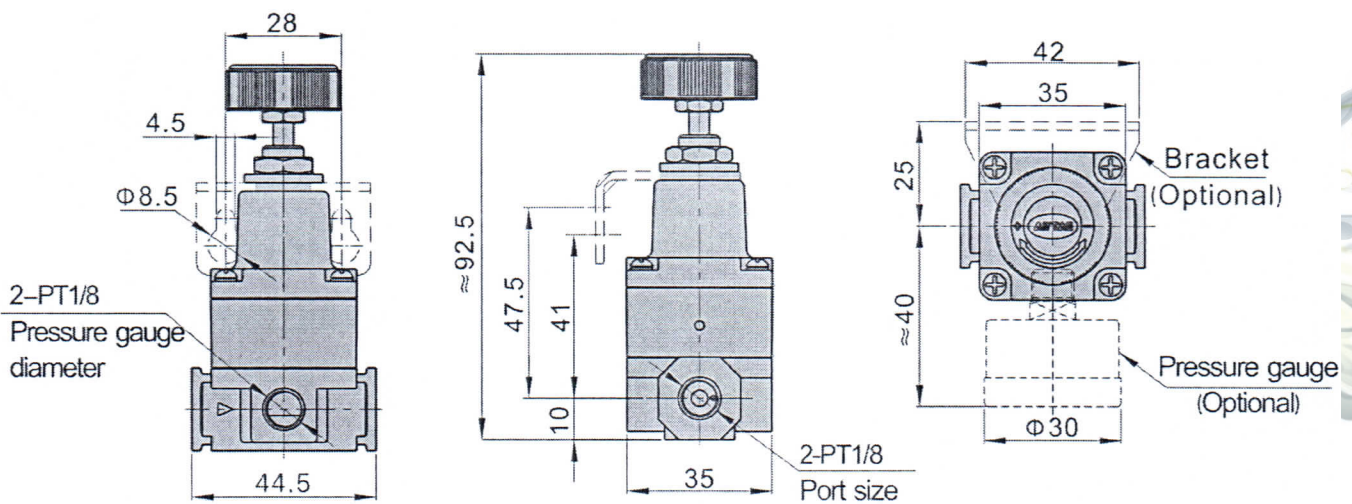

## Dimensions

### GPR300 Dimensions

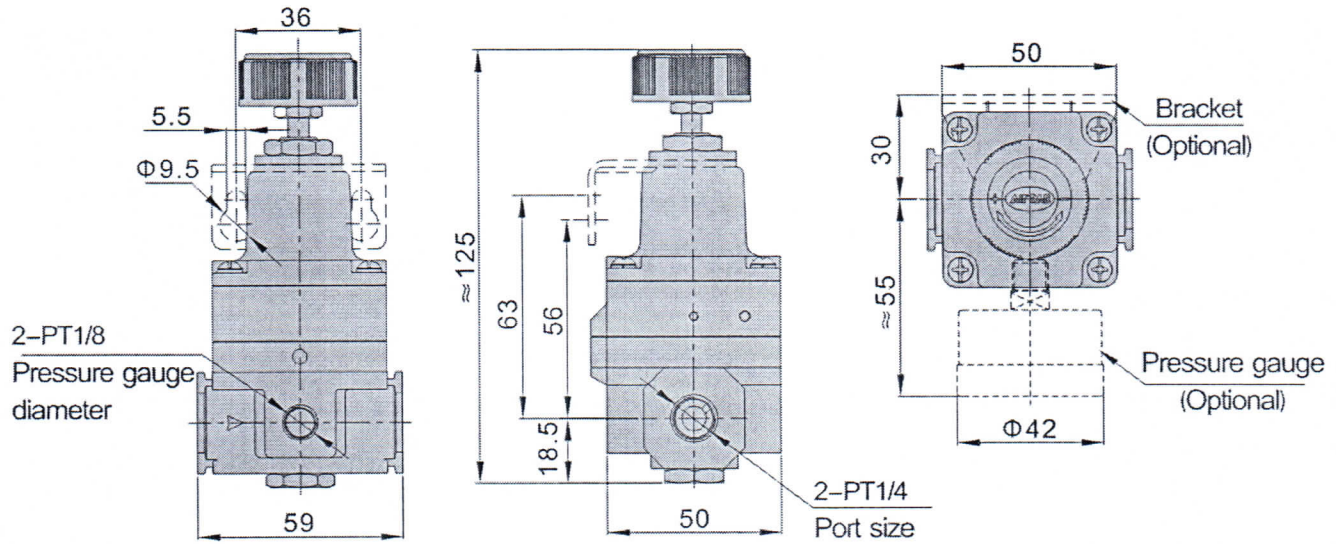

### GPR400 Dimensions

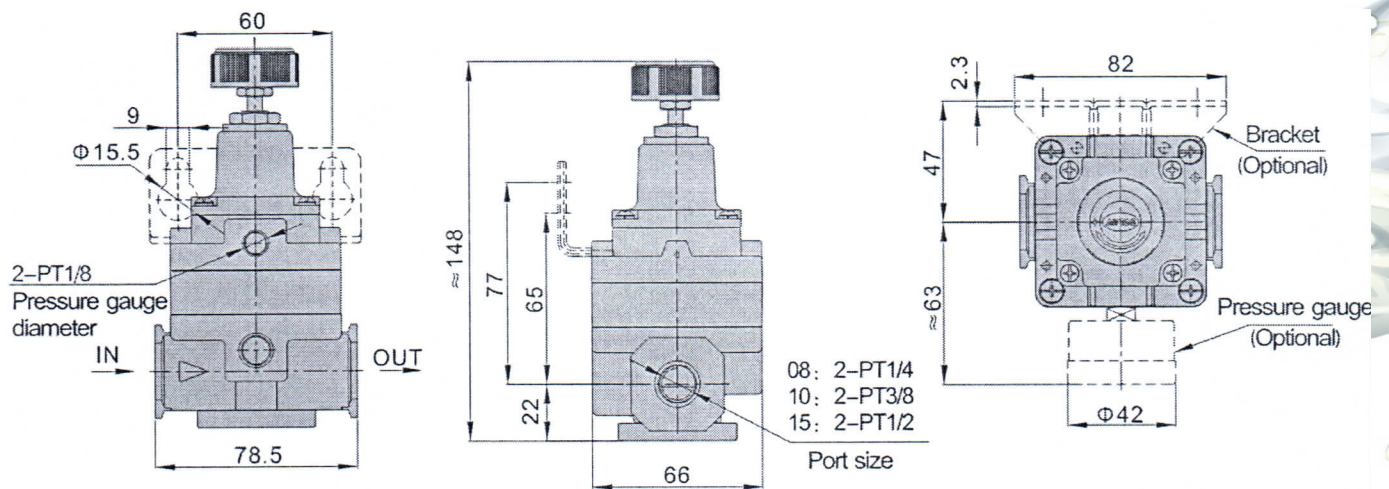

## Inner Structure

### GPR300

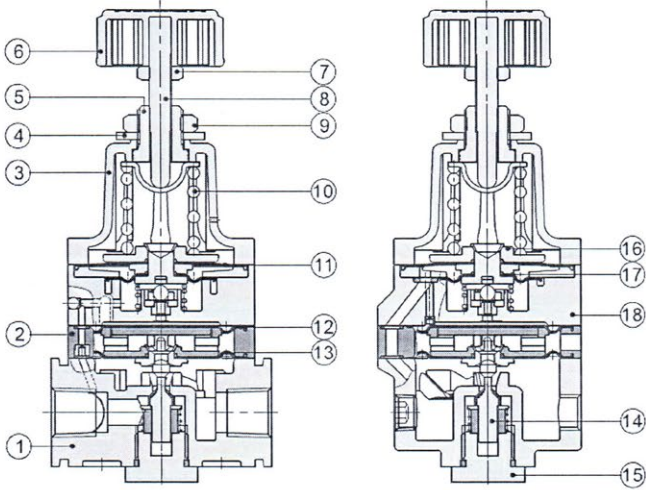

No.	Item	Material
1	Regulator body	Aluminium alloy
2	Pilot body	Plastic
3	Regulator seat	Aluminum alloy
4	Bracket gasket	SPCC
5	Adjusting nut	Carbon steel
6	Regulator knob	Plastic
7	Nut	Carbon steel
8	Regulator spindle	Carbon steel
9	Nut	Carbon steel
10	Spring	Spring steel
11	Pilot upper diaphragm	NBR
12	Regulator upper diaphragm	NBR
13	Regulator lower diaphragm	NBR
14	Main valve	Stainless steel + NBR
15	Bonnet	Carbon steel
16	Pilot diaphragm upper hard core	Aluminum alloy
17	Pilot lower diaphragm	NBR
18	Nozzle body	Aluminum alloy

## Advantages

- Good diaphragm properties and long service life

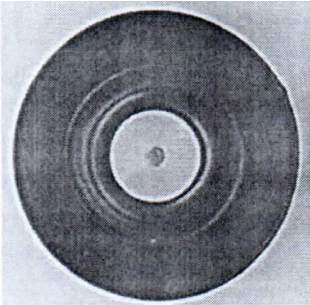

**KELM™ diaphragm**  
(measured 2 million times)



**SMC diaphragm**  
(measured 1.5 million times)

## Installation and Application

- If the supply pressure line contains drain or particulate, etc, the fixed throttle can become clogged leading to malfunction, and therefore, in addition to an air filter (Series GF) be sure to use a mist separator (Series GPF)
- Never use a lubricator on the supply side of the regulator, as this will positively cause the fixed throttle to become clogged and result in a malfunction. If lubrication is required for terminal devices, connect a lubricator on the output side of the regulator
- If a directional switching valve (solenoid valve, mechanical valve, etc.) is mounted on the supply side of the regulator and repeatedly switch ON and OFF, wear of the nozzle/flapper section will be accelerated and a discrepancy in the setting valve may occur. Therefore, avoid using a directional switching valve on the supply side. In the event a directional switching valve will be used, install it on the output side of the regulator
- Air is normally released from the bleed hole (the hole on the side of the body's mid-section). This is a necessary consumption of air based on the construction of the precision regulator, and is not an abnormality
- Make sure to tighten the lock nut after pressure adjustment