



# Oval Type Flow Meters



## Description

Oval type flow meters are a complete flow measurement and monitoring system for re-circulating oil systems.

The method of measurement is based on the rotation of special oval designed gears – the speed of which changes in proportion to the flow of oil through the meter. This gives a visual indication of the flow rate through the transparent cover and also sends electrical pulse signals to an electronic monitor or PLC to provide actual flow figures.

This also provides information to allow either low or high flow monitoring to be provided.

## Benefits

Measurement is independent of viscosity and therefore a real flow will be indicated throughout the temperature range.

Pressure drop through the flow meter is relatively low.

The flow meter is designed to pass a small flow even if the gears are prevented from turning due to solid particles contained in the oil. This prevents complete starvation of oil to bearings etc.

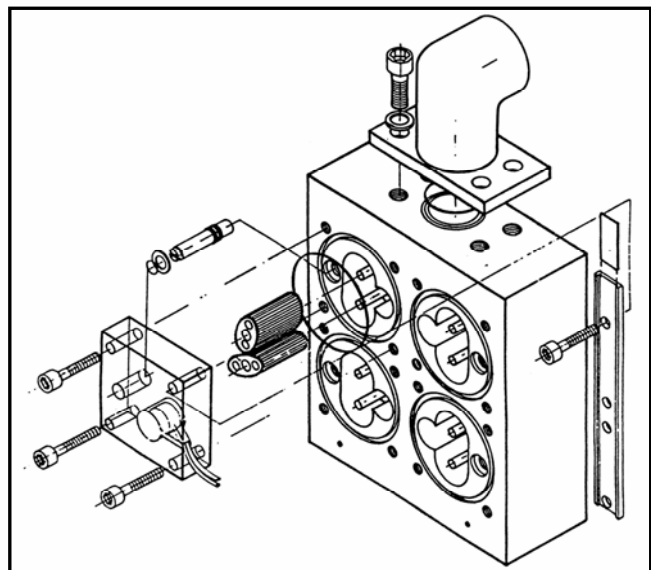

## Operation

Their oval design and the flow of oil passing through the meter affect the rotation of the gears. The differential pressure within the meter produces a rotational force

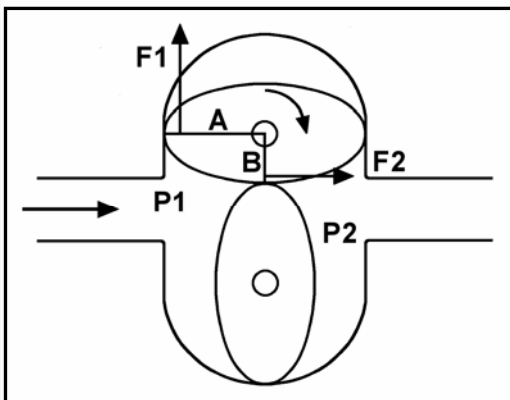

$$A/B = F1/F2$$

Where: A = the largest radius of the oval gear  
 B = the smallest radius of the oval gear  
 F1 = the force caused by radius A  
 F2 = the force caused by radius B

Oil flows around the outside of the two gears that mesh in the centre.

The proximity sensor produces two pulses per operation of the gear.

An adjustable needle valve is incorporated into the design to allow the flow rate to be set. This valve is viscosity sensitive so that during cold start-up conditions, there will be a reduced oil flow through the meter.

## Specification

The flow meters are available in different sizes to cover a wide range of flows. The smallest sizes (up to 6 litres per minute) can be supplied in combination blocks with 2, 4, 6 or 8 outlets from a common supply connection.

Model	Maximum Flow Rate Litres Per Minute	Pulses Per Litre
SRx - 1	1	1965
SRx - 2	2	1200
SRx - 6	6	300
SR - 10	10	125
SR - 20	20	74.5
SR - 30	30	49.5
SR - 60	60	22
SR - 100	100	12.5

NOTE:- x refers to the number of outlets in each assembly.

Under normal operating conditions it is not advisable to exceed the above stated maximum flow rate. However, the flow meters can withstand 2 or 3 times this flow for a momentary period.

Accuracy - The oval type flow meter has an accuracy of + or – 5% over the whole of the flow measurement range.

Pressure Loss - This largely depends on the pressure drop across the adjustable needle valve and the viscosity of the oil. In most cases this will be less than 0.5 bar but a check needs to be made if high viscosity oil is being used.

Maximum Pressure - 10 bar.

Maximum Temperature - 80°C.

Electrical Sensor - Proximity switch 10 – 30 V DC PMP type.

## Installation

Oval gear meters must be installed so that the gear shafts are horizontal. During installation, it is important that the oil supplied and all pipes/connections are free from impurities.