

3 Ways Brass Ball Valve PN25 Threaded

Size: DN 1/4" to 3"

Ends: Threaded Female BSP

Min Temperature: -10°C

Max Temperature: +100°C

Max Pressure: 25 Bars

Specifications: PTFE packing (except DN 3")

3 Positions

3 ways

Materials: Brass



3 WAYS BRASS BALL VALVE PN25 THREADED

SPECIFICATIONS :

- Full bore Ref. 534
- 3 Positions
- PTFE packing (Except DN 3")
- No anti blow out stem
- 3 ways
- Solid ball
- L port

USE :

- For all common fluids
- Min and max Temperature Ts : -10°C to + 100°C
- Max Pressure Ps : 25 bars (see graph)
- Differential pressure : 5 bars maxi

PRESSURE / TEMPERATURE GRAPH (STEAM EXCLUDED) :

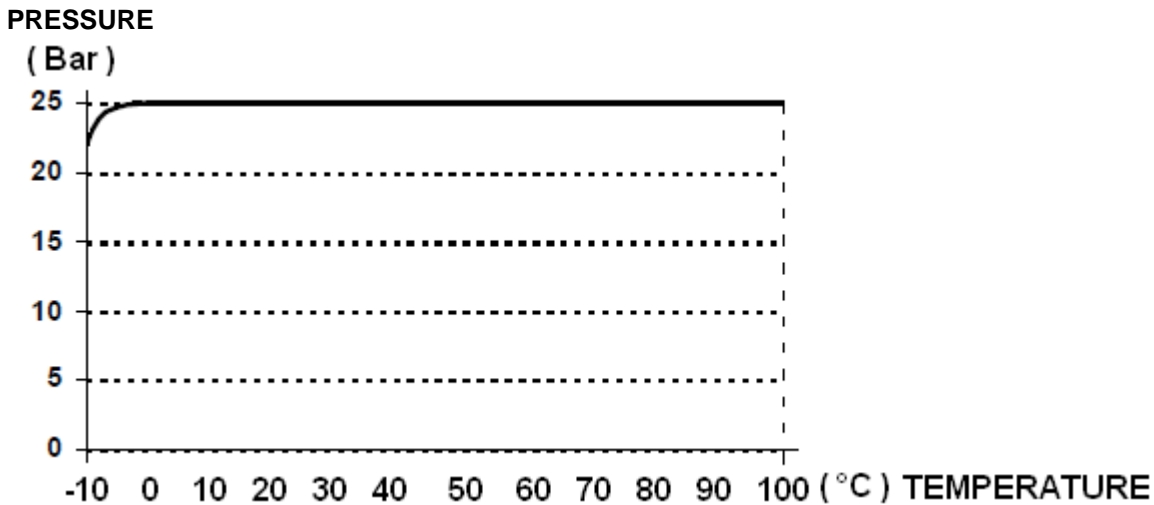

RANGE :

- Threaded female BSP cylindrical, L port **Ref. 534** from DN 1/4" to 3"

ENDS :

- Threaded female BSP cylindrical

3 WAYS BRASS BALL VALVE PN25 THREADED

MATERIALS :

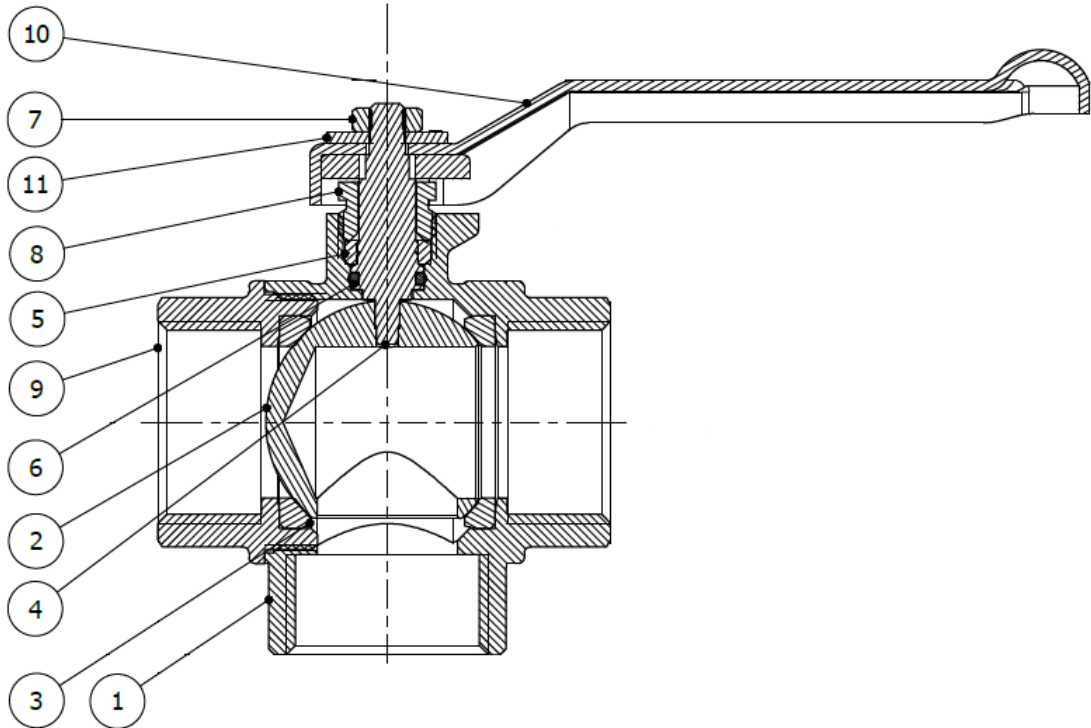

Item	Designation	Materials
1	Body	Brass CW 617 N according to EN 12165
2	Ball	Brass CW 614 N according to EN 12164
3	Seat	PTFE
4	Stem	Brass CW 614 N according to EN 12164
5*	Packing	PTFE
6	O ring	FKM
7	Handle nut	Steel UNI 7356-CB4FF
8	Packing nut	Brass CW 614 N according to EN 12164
9	Ends	Brass CW 617 N according to EN 12165
10	Handle	Steel EN1011-DD13
11	Washer	Aluminium EN7639-SGALSI 1

(*) : For DN 3", PTFE packing is substituted by 2 o ring

3 WAYS BRASS BALL VALVE PN25 THREADED

POSSIBLE POSITIONS :

L port (Ref. 534)

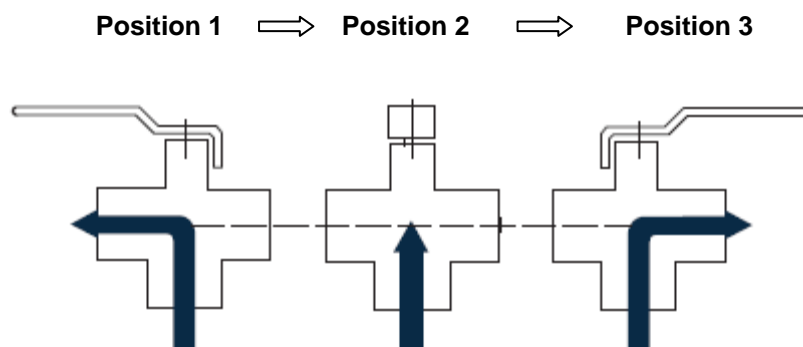

3 WAYS BRASS BALL VALVE PN25 THREADED

SIZE FOR L PORT REF.534 (in mm) :

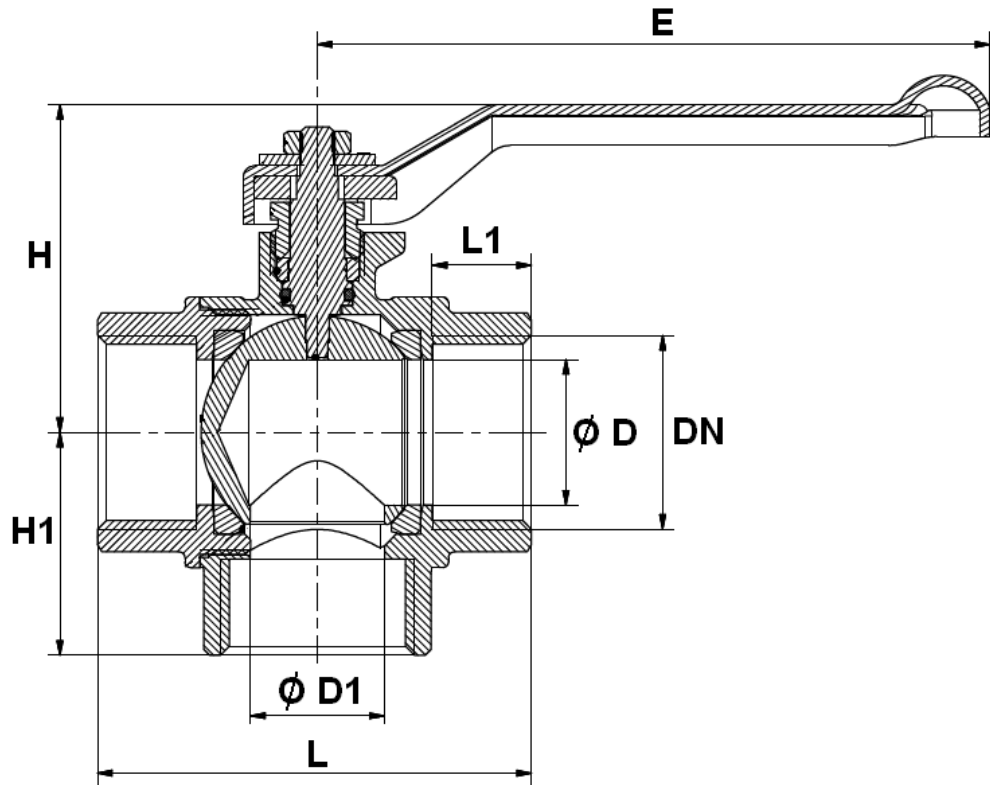

Ref.	DN	1/4"	3/8"	1/2"	3/4"	1"	1"1/4	1"1/2	2"	3"
534	Ø D	10	10	12	20	25	32	39	48	80
	Ø D1	10	10	12	18	23	30	37	46	80
	L	53	53	54.5	66.5	74.5	85	97	109	177
	L1	14	14	14	16	17	18	19	21	25
	E	92	92	92	92	115	150	150	150	240
	H	48	48	48	50	55	62	62	62	129
	H1	31	30.5	30.5	34.5	38	46	53	62.5	115
	Weight (Kg)	0.385	0.358	0.311	0.428	0.636	0.970	1.539	2.332	7.636

3 WAYS BRASS BALL VALVE PN25 THREADED

STANDARDS :

- Fabrication according to ISO 9001 : 2008
- DIRECTIVE 2014/68/EU : Products excluded from directive (Article 1, § 2.b)
- French water agreement **A.C.S. N° 15 ACC LY 312**
- Threaded BSP cylindrical according to ISO 228-1

3 WAYS BRASS BALL VALVE PN25 THREADED

INSTALLATION INSTRUCTIONS

GENERAL GUIDELINES :

- Ensure that the valves to be used are appropriate for the conditions of the installation (type of fluid, pressure and temperature).
- Be sure to have enough valves to be able to isolate the sections of piping as well as the appropriate equipment for maintenance and repair.
- Ensure that the valves to be installed are of correct strength to be able to support the capacity of their usage.
- Tighten the gland packing regularly to keep the stem in the right position
- **Installation of all circuits should ensure that their function can be automatically tested on a regular basis (at least two times a year).**

INSTALLATION INSTRUCTIONS :

- **Before installing the valves, clean and remove any objects from the pipes** (in particular bits of sealing and metal) which could obstruct and block the valves.
- **Ensure that both connecting pipes either side of the valve (upstream and downstream) are aligned (if they're not, the valves may not work correctly).**
- **Make sure that the two sections of the pipe (upstream and downstream) match, the valve unit will not absorb any gaps. Any distortions in the pipes may affect the tightness of the connection, the working of the valve and can even cause a rupture.** To be sure, place the kit in position to ensure the assembling will work.
- Before starting the fitting, ensure that the threads and tapping are clean.
- **If sections of piping do not have their final support in place, they should be temporarily fixed. This is to avoid unnecessary strain on the valve.**
- The theoretical lengths given by ISO/R7 for the tapping are typically longer than required, the length of the thread should be limited, and **check that the end of the tube does not press right up to the head of the thread.**
- Position the pipe clips on both sides of the valve.
- If mounting on an air conditioning with PER tubing and hoses, it is necessary to support the tubes and hoses with the fixing to avoid strain on the valve.
- When screwing the valve, ensure that you only rotate on screwed side by the 6 ended side. Use an open ended spanner or an adjustable spanner and not a monkey wrench.
- **Never use a vice to tighten the fixings of the valve.**
- Do not over tighten the valve. Do not block with any extensions as it may cause a rupture or weakening of the casing.
- **In general, for all valves used in buildings and heating, do not tighten above a torque of 30 Nm.**

The advice and assembly instructions above do not conform to any guarantee.
The information is given in general. It states what must not and must be done.
It is provided to ensure the safety of the personnel and the reliability of the valves.
The instructions in bold must be followed.