

Dry Cleaned Brass Ball Valve (502-520-561)

Size: DN 1/4" to 2"

Ends: Female, Female or male-male BSP

Min Temperature: - 20°C

Max Temperature: +160°C

Max Pressure: 40 Bars (up to DN1")

Specifications: Anti blow-out stem
PTFE packing + EPDM O ring on stem
Full bore

Materials: Brass CW 617 N according to EN 12165



DRY CLEANED BRASS BALL VALVE (502-520-561)

SPECIFICATIONS :

- Dry cleaned for oxygen
- Valves in plastic individual closed sachet
- Long threaded ends
- Full bore
- Anti blow-out stem
- Solid ball
- PTFE packing + EPDM stem O ring
- White flat steel handle or white aluminium butterfly handle
- Female or male cylindrical threaded BSP

USE :

- Oxygen, argon, azote ...
- Do not use with acetylene
- Min Temperature Ts : - 20 °C
- Max Temperature Ts : + 120°C
- Max Pressure Ps : 40 up to DN 1", 32 bars for DN 1"1/4, 30 bars for DN 1"1/2, 25 bars for DN 2" (see graph under)

PRESSURE / TEMPERATURE GRAPH (STEAM EXCLUDED) :

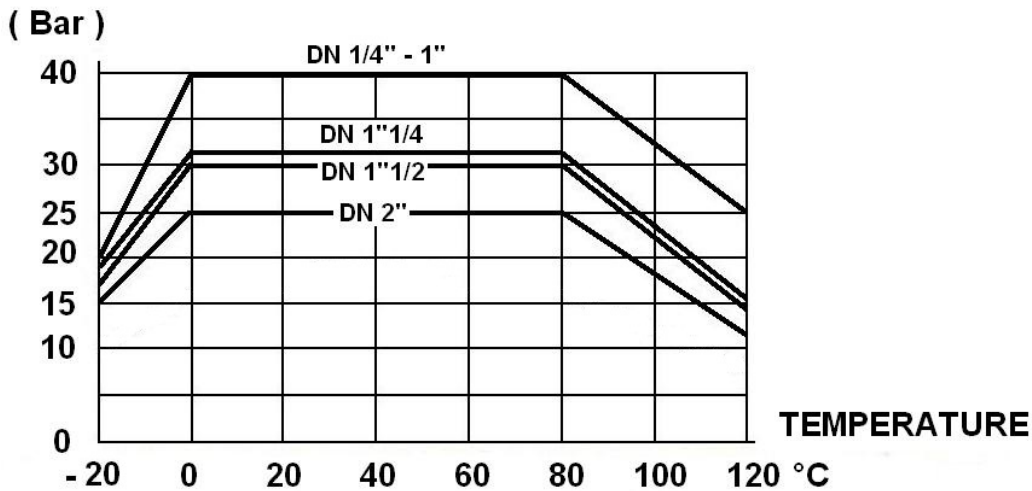

RANGE :

- Female / Female threaded BSP with white flat steel handle **Ref. 520** from DN 1/4" to 2"
- Female / Female threaded BSP with white aluminium butterfly handle **Ref. 561** from DN 1/4" to 1"
- Male / Male threaded BSP with white flat steel handle **Ref. 502** from DN 3/8" to 2"
- Male / Male threaded BSP with white aluminium butterfly handle **Ref. 5021** from DN 3/8" to 1"

DRY CLEANED BRASS BALL VALVE (502-520-561)

MATERIALS MALE-MALE TYPES REF. 502 AND 5021 :

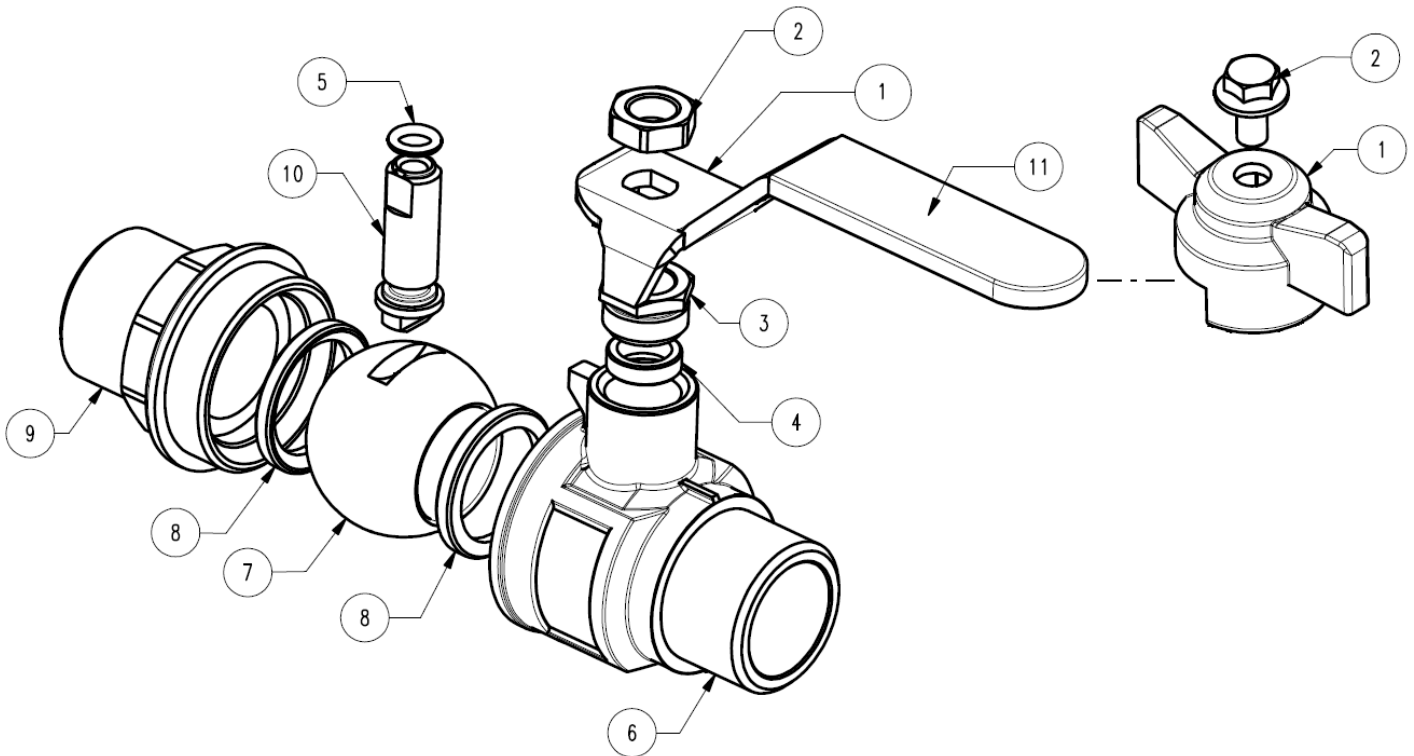

Item	Designation	Materials 502	Materials 5021
1	Handle	Galvanized steel	Aluminium
2	Handle nut or screw	Steel	
3	Packing nut	Brass CW 614 N according to EN 12164	
4	Packing	PTFE	
5	O ring	EPDM	
6	Body	Nicked brass CW 617 N according to EN 12165	
7	Ball	Chromed brass CW 617 N according to EN 12165	
8	Seat	PTFE	
9	Bonnet	Nicked brass CW 617 N according to EN 12165	
10	Stem	Brass CW 614 N according to EN 12164	
11	Handle cover	Plastic	-

DRY CLEANED BRASS BALL VALVE (502-520-561)

SIZE MALE-MALE TYPES REF.502 AND 5021 (in mm) :

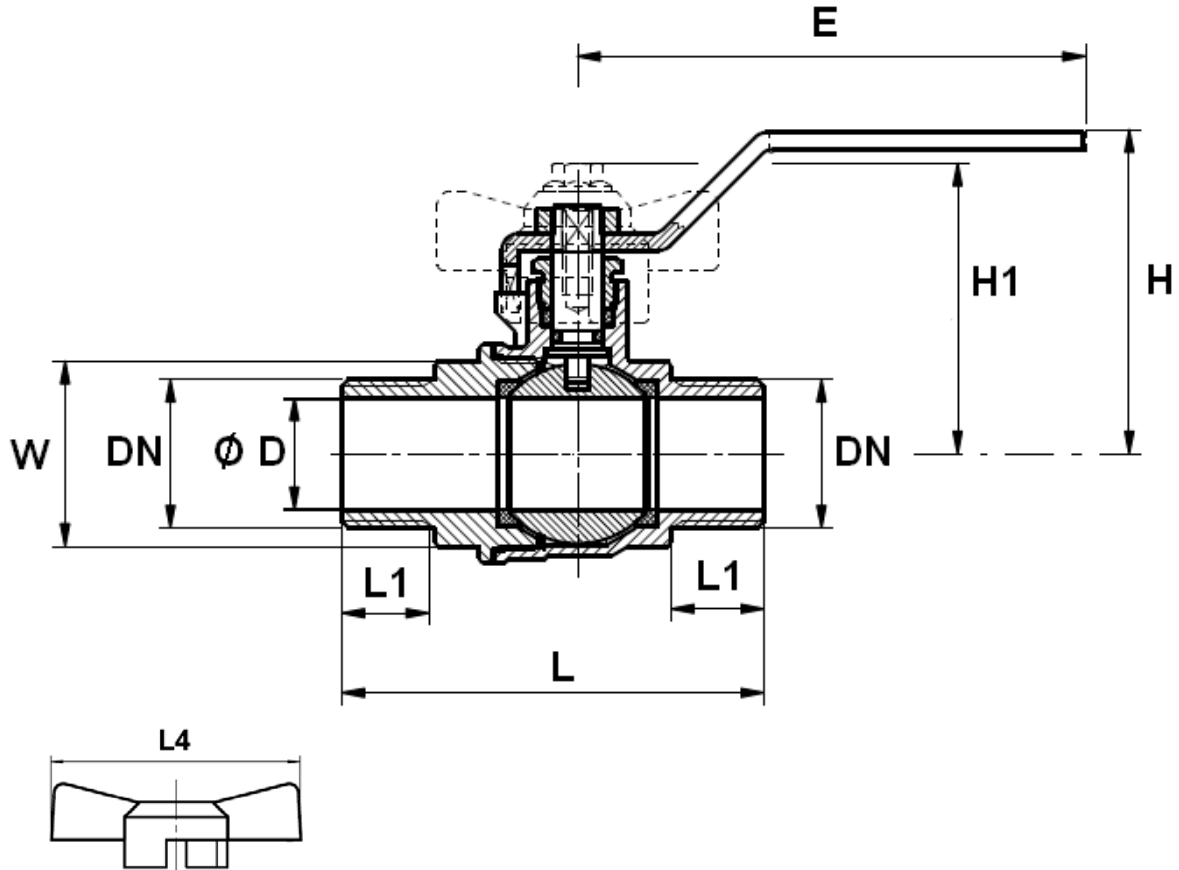

(Ref. 5021)

Ref.	DN	3/8"	1/2"	3/4"	1"	1"1/4	1"1/2	2"
502	Ø D	10	15	20	25	32	40	50
	L	51.5	65.5	75.5	85.5	89	102	116.5
	L1	11.5	15	16.5	19.5	16	17	18
	L4	50	50	50	65	-	-	-
5021	E	80	90	90	130	130	130	150
	H	40.5	53.5	57.5	66.5	72	78	91.5
	H1	37.5	48	52	62.5	-	-	-
502	W on flat	21	26	31	38	42	48	60
502	Weight (in Kg)	0.135	0.260	0.360	0.610	0.745	1.025	1.840
5021	Weight (in Kg)	0.120	0.250	0.350	0.545	-	-	-

DRY CLEANED BRASS BALL VALVE (502-520-561)**STANDARDS :**

- Fabrication according to ISO 9001 : 2008
- DIRECTIVE 2014/68/EU : Products excluded from directive up to DN1" (Article 4, § 3)
Risk category I module A from DN1"1/4 to DN2"
- Threaded male and female cylindrical BSP ends according to ISO 228-1
- Degreased according to NF EN 12300

DRY CLEANED BRASS BALL VALVE (502-520-561)**INSTALLATION INSTRUCTIONS****GENERAL GUIDELINES :**

- Ensure that the valves to be used are appropriate for the conditions of the installation (type of fluid, pressure and temperature).
- Be sure to have enough valves to be able to isolate the sections of piping as well as the appropriate equipment for maintenance and repair.
- Ensure that the valves to be installed are of correct strength to be able to support the capacity of their usage.
- **Installation of all circuits should ensure that their function can be automatically tested on a regular basis (at least two times a year).**

INSTALLATION INSTRUCTIONS :

- **Before installing the valves, clean and remove any objects from the pipes** (in particular bits of sealing and metal) which could obstruct and block the valves.
- **Ensure that both connecting pipes either side of the valve (upstream and downstream) are aligned (if they're not, the valves may not work correctly).**
- **Make sure that the two sections of the pipe (upstream and downstream) match, the valve unit will not absorb any gaps. Any distortions in the pipes may affect the tightness of the connection, the working of the valve and can even cause a rupture.** To be sure, place the kit in position to ensure the assembling will work.
- Before starting the fitting, ensure that the threads and tapping are clean.
- **If sections of piping do not have their final support in place, they should be temporarily fixed. This is to avoid unnecessary strain on the valve.**
- The theoretical lengths given by ISO/R7 for the tapping are typically longer than required, the length of the thread should be limited, and **check that the end of the tube does not press right up to the head of the thread.**
- Position the pipe clips on both sides of the valve.
- If mounting on an air conditioning with PER tubing and hoses, it is necessary to support the tubes and hoses with the fixing to avoid strain on the valve.
- When screwing the valve, ensure that you only rotate on screwed side by the 6 ended side. Use an open ended spanner or an adjustable spanner and not a monkey wrench.
- **Never use a vice to tighten the fixings of the valve.**
- Do not over tighten the valve. Do not block with any extensions as it may cause a rupture or weakening of the casing.
- **In general, for all valves used in buildings and heating, do not tighten above a torque of 30 Nm.**

The advice and assembly instructions above do not conform to any guarantee.
The information is given in general. It states what must not and must be done.
It is provided to ensure the safety of the personnel and the reliability of the valves.
The instructions in bold must be followed.