

# Full Flow Gas Ball Valves London®

## 069

LONDON®  
BALL VALVE,  
FULL FLOW



SIZE	PRESSURE	CODE	PACKING
1/4" (DN 8)	5bar/72,5psi	BV69-14	15/165
3/8" (DN 10)	5bar/72,5psi	BV69-38	15/165
1/2" (DN 15)	5bar/72,5psi	BV69-12	10/130
3/4" (DN 20)	5bar/72,5psi	BV69-34	8/64
1" (DN 25)	5bar/72,5psi	BV69-1	6/48

### TECHNICAL SPECIFICATIONS

#### EN 331 APPROVED.

Male/female threads.

Body in nickel-plated brass.

T handle in aluminium.

Minimum and maximum working temperatures: -20°C to +60°C.

Female thread ISO 7/1 Rp parallel

(equivalent to DIN EN 10226-1 and BS EN 10226-1).

Male thread ISO 7/1 R taper

(equivalent to DIN EN 10226-1 and BS EN 10226-1).

### MATERIALS

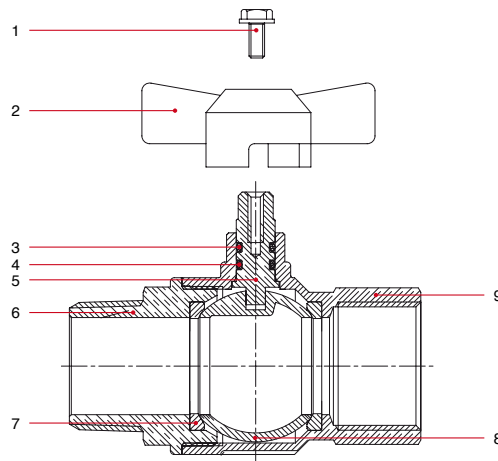

POS.	DESCRIPTION	N.	MATERIAL
1	Screw	1	Zinc-plated steel Fe CB4
2	T handle	1	Varnished aluminium
3	O-Ring	1	VITON®
4	O-Ring	1	NBR
5	Stem	1	Brass CW614N
6	End adapter	1	Nickel-plated brass CW617N
7	Seat	2	PT.FE.
8	Ball	1	Chrome-plated brass CW617N
9	Body	1	Nickel-plated brass CW617N

## OVERALL DIMENSIONS

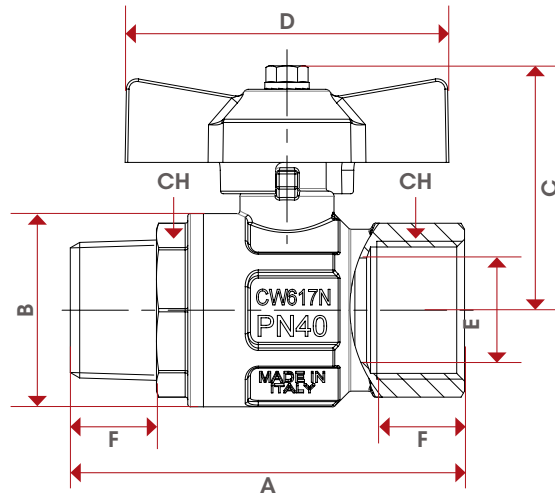

	1/4"	3/8"	1/2"	3/4"	1"
DN	8	10	15	20	25
A	56,9	58,9	68	75,5	90,5
B	23,5	24	30,5	37	45,5
C	37,3	37,3	48,8	46,8	50,8
D	47	47	54	62	62
E	8	10	15	20	25
F	11	11,4	15	16,3	19,1
CH	18	21	25	31	38
Kg/cm <sup>2</sup> bar	5	5	5	5	5
LBS - psi	72,5	72,5	72,5	72,5	72,5

## CERTIFICATIONS

